



Sustainability has never been this accessible

Ver 0.3.3.1 (c)
Jan 2021

Commercial and confidential information not for distribution without authorisation

Who are we



NeuerEnergy is powered by Aqovia

NeuerEnergy is a spinout venture from Aqovia

Aqovia is an international technology platform and solutions specialist, combining applied innovation and transformation across both public and private sectors.

Our platforms and solutions are being used by some of the worlds well known brands, which include:



An aerial night view of a city with a glowing network overlay. The city lights are visible in the background, and the network consists of blue nodes and connecting lines, suggesting a digital or technological theme.

Technology and Features

Price and cost benefits

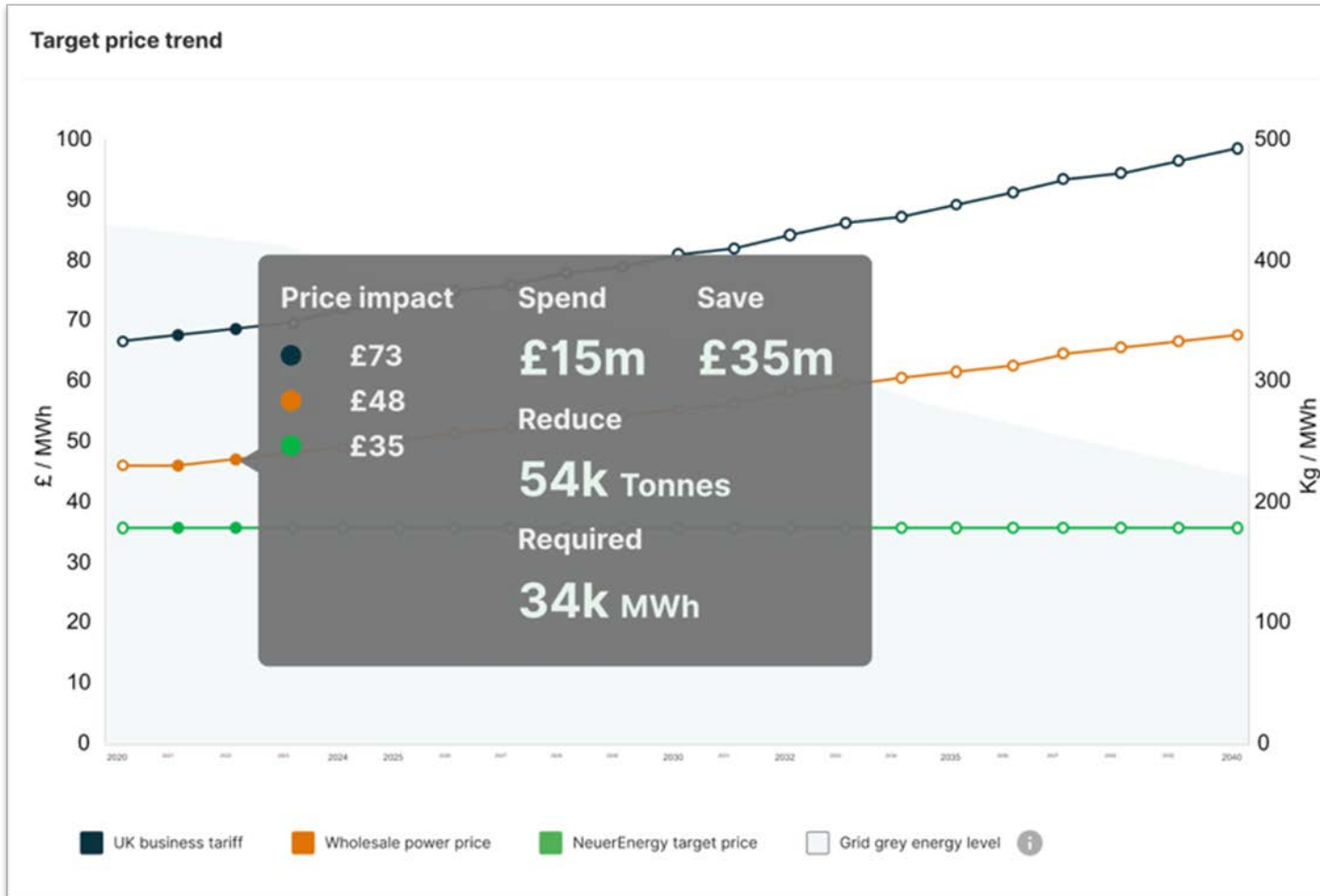

You'll save

£6.22m

Savings over 5 years

You'll reduce

52k Tonnes

CO₂ reduction over 5 years

You'll require

0.1m MWh

Required energy over 5 years

Project roadmap

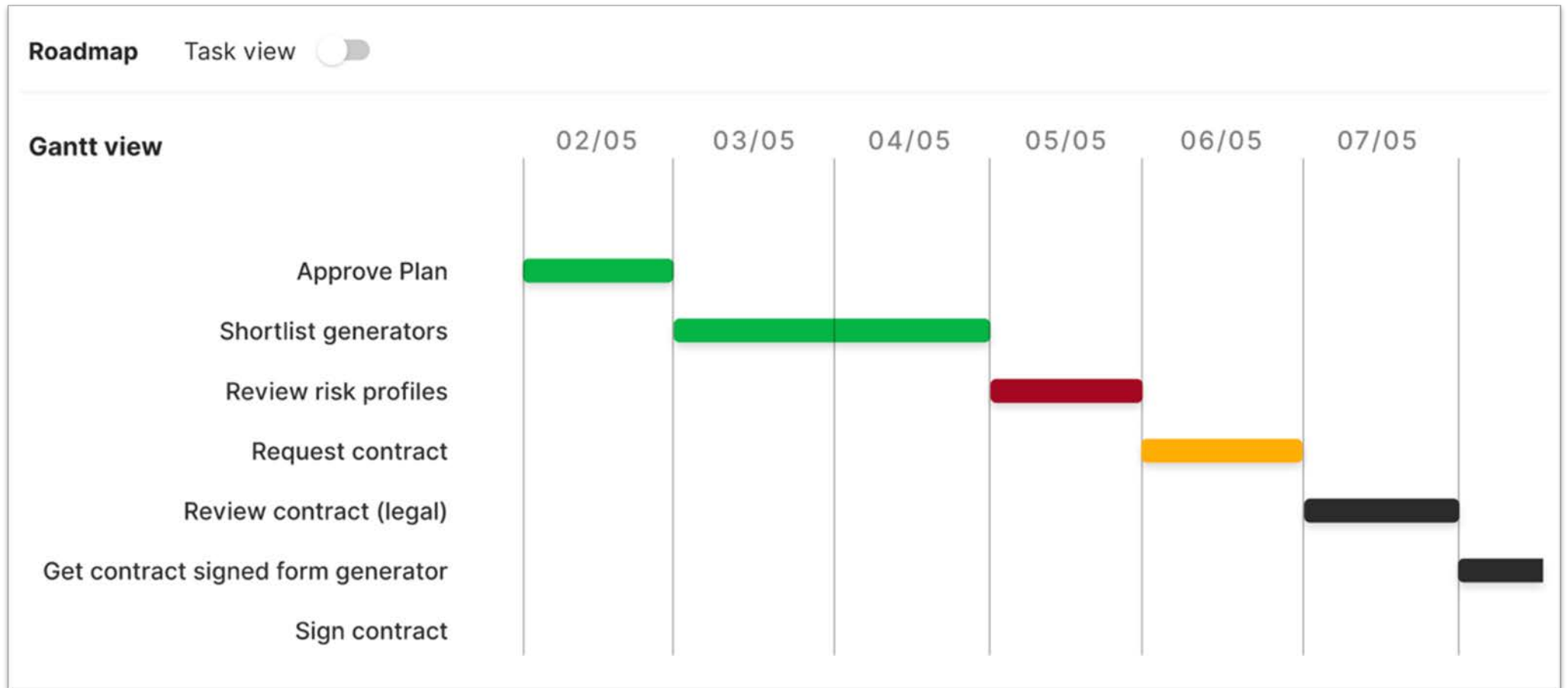

Consensus building



Approval 0/1

Approval requested by:  Owen Maestro

We have done the Carbon footprint and price analysis. Could you please review this Business Impact summary and give your approval?

Name	Role	Status	Deadline	
 Grace Jacobson	Approver	● Requested	05/02/2021	<input type="button" value="APPROVE"/> <input type="button" value="REJECT"/>

Add legal service provider to review contract

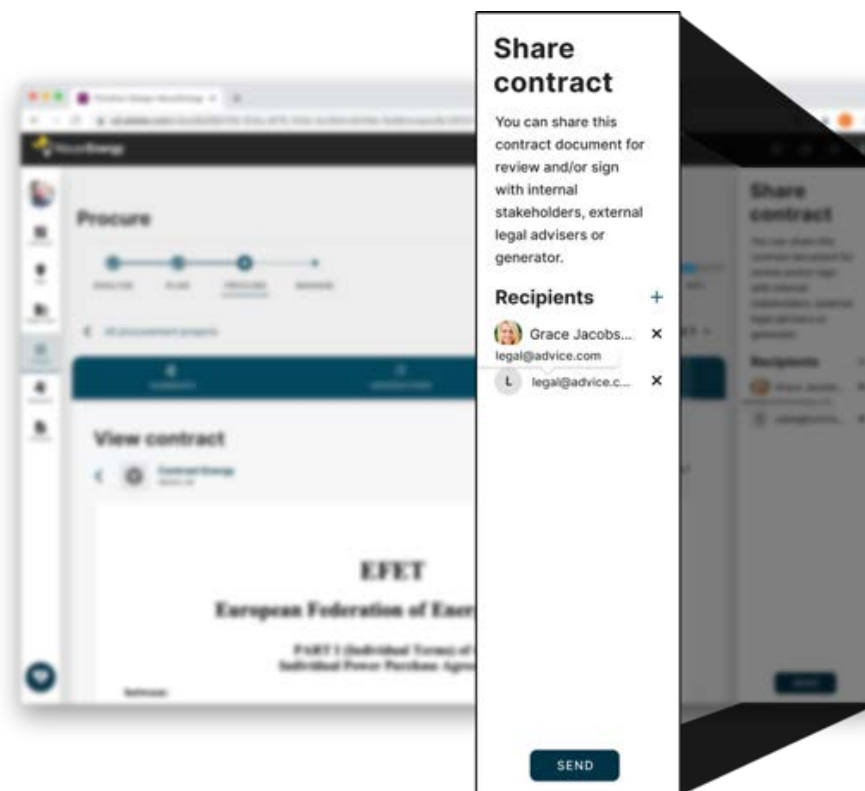
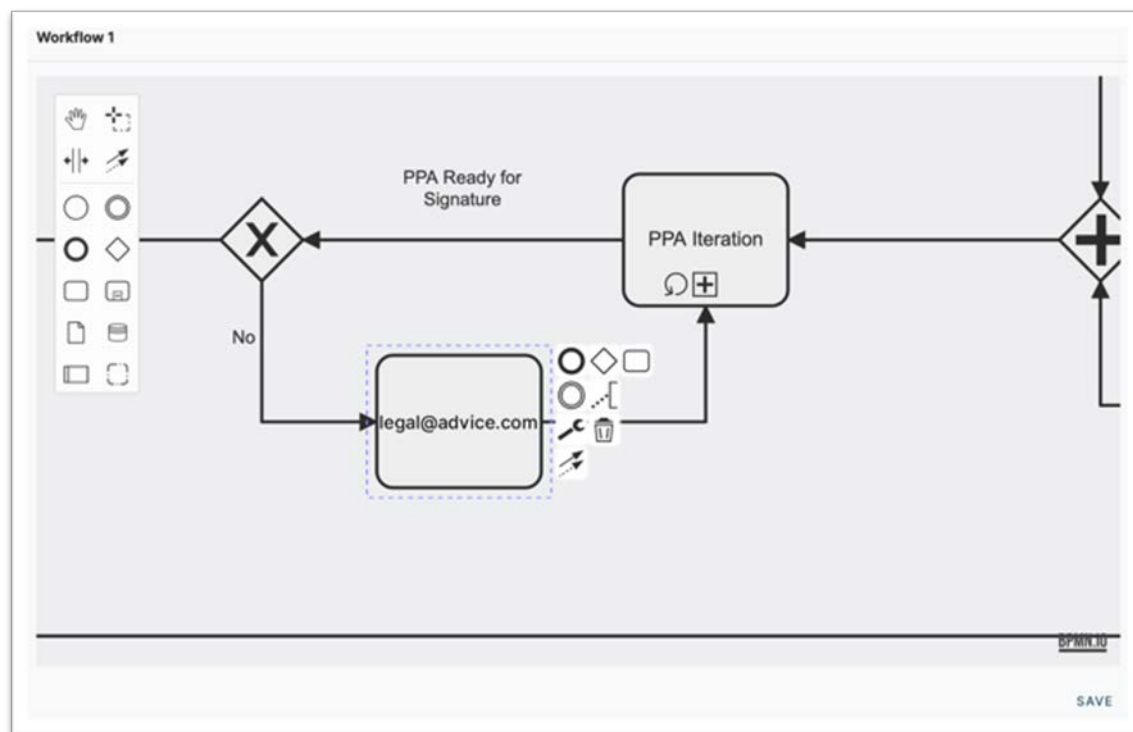

Project roadmap

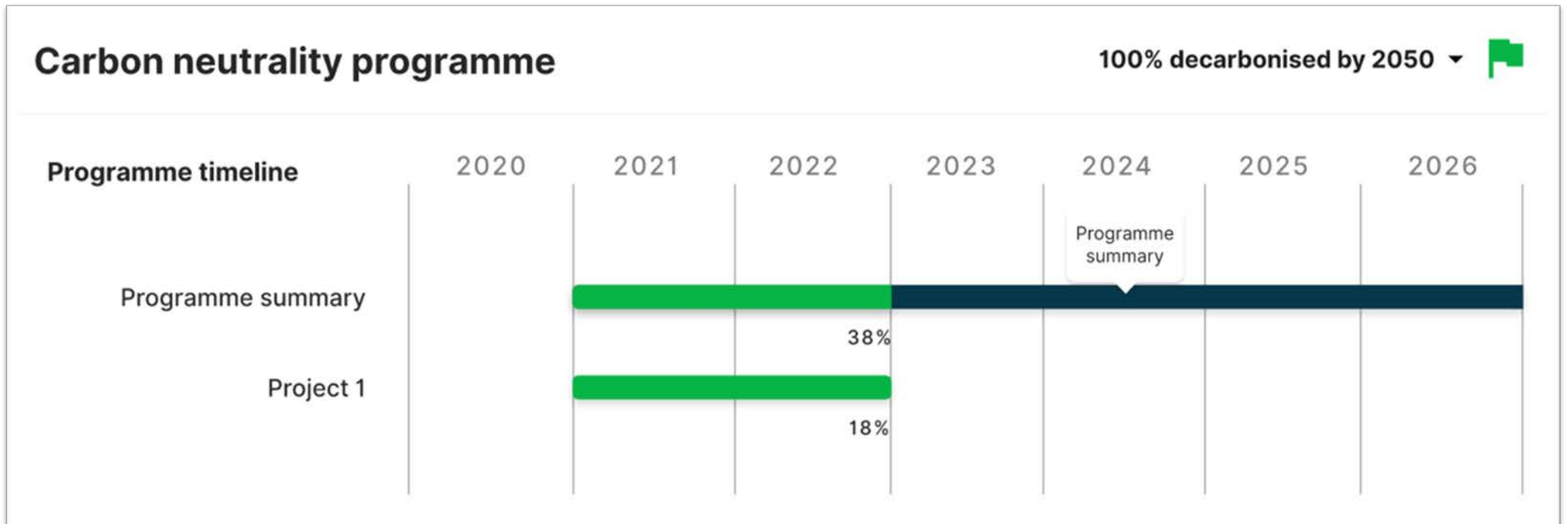

Risk management

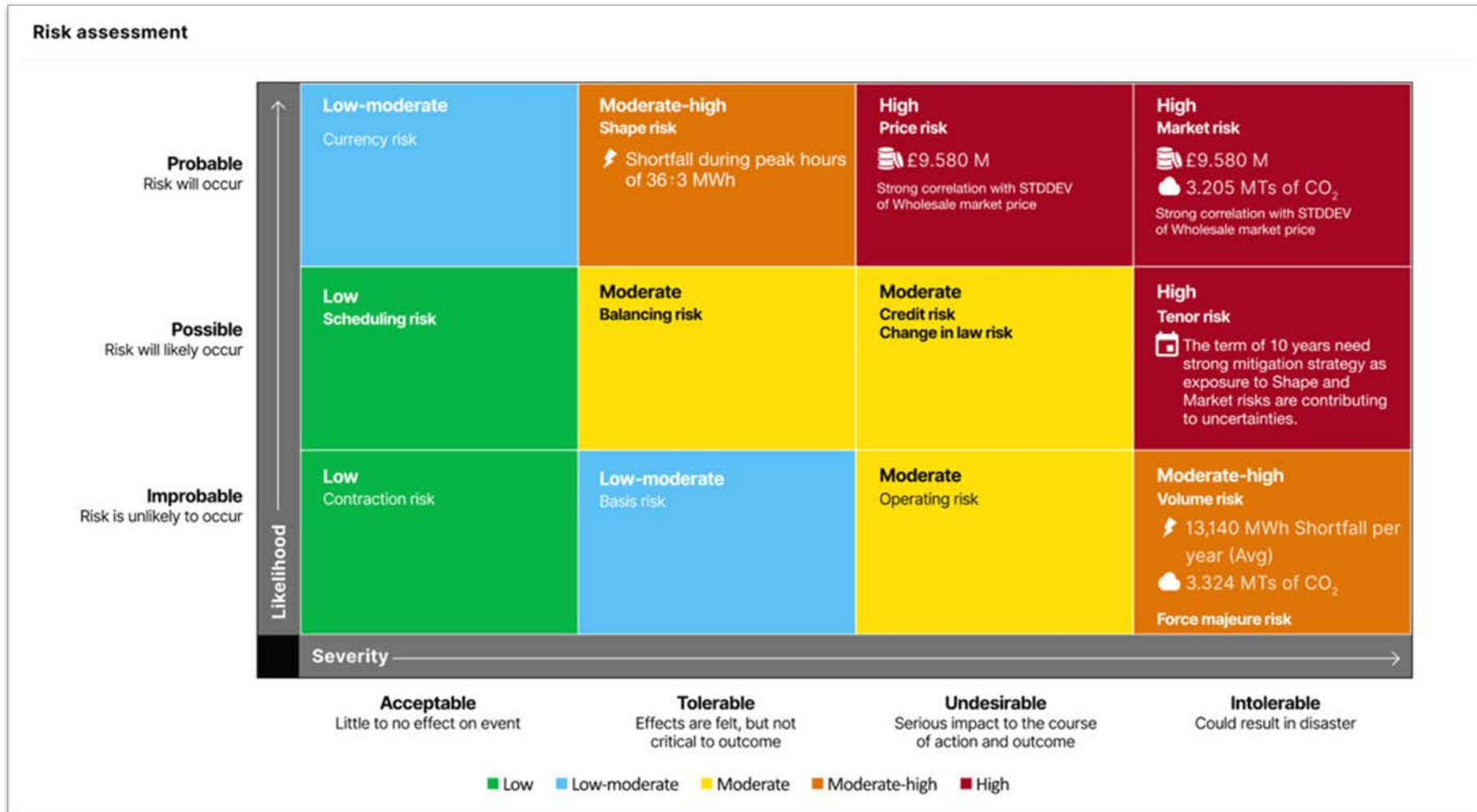

Subscribe and take advantage of simple and streamlined workflow and role-based intelligence

The NeuerEnergy API can pull in all your energy business intelligence data, accessing silos of data within any technology ecosystem, including any existing PPAs, REGOs and/or iRECs.



Single version of the truth

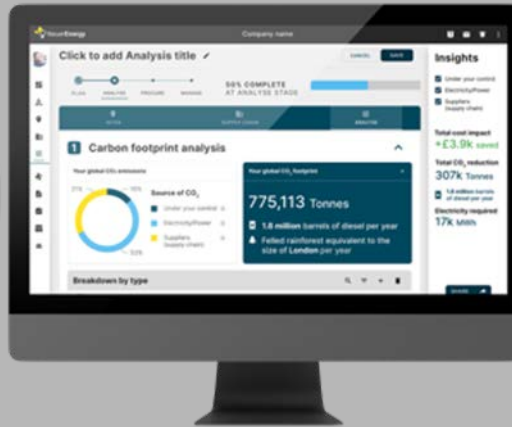

Plan | Procure | Manage

Intelligent & Integrated



Forecast management

Demand management

Risk management



Risks

Price Fuels

Climate Currency



Underwriting

Legal



Workflow

Transparency



Renewable certificate

REGOs
RECs iRECs

Blockchain

Pricing

Weather

Satellite

Datasets

Algorithms



Removing the barriers to corporate carbon neutrality

199 Bishopsgate,
London EC2M 3TY
United Kingdom
+44 207 242 2956