

# **Grid integration and stability of 600MW windfarm at Kriegers Flak – the largest power plant in Denmark**

Vladislav Akhmatov

Energinet.dk Transmission System Operator of Denmark, Fredericia, Denmark

## **1. Abstract**

When completed by December 2018, the Kriegers Flak 600MW offshore wind power plant (OWPP) will be the largest electrical power generation unit in Denmark East. Including the Kriegers Flak OWPP, the nominal wind power capacity will correspond to 65% of the maximum and 210% of the minimum electrical power consumption, respectively. Already in fair wind conditions, the wind power, decentralised combined heat and power (CHP) units and photovoltaics (PV) will cover the most of electrical power consumption. Participation of centralised thermal power plants will be significantly reduced. The power and energy balance will be maintained through utilization of interconnectors to the neighbouring systems. This paper describes the approach and main findings of the dynamic stability study for Denmark East, which Energinet.dk has conducted by summer 2015 for the grid-connection of the Kriegers Flak 600MW OWPP. Among the novices and challenges are that an OWPP becomes the largest power generation unit in the transmission system, a significant share of fixed-speed wind turbines with induction generators in Denmark East, and operation scenarios with no participation of centralised thermal power plants. The study outline represents a realistic near-future horizon for the Danish transmission system though stressed operation pre-conditions. The study has shown that the transmission system of Denmark East remains dynamically stable to short-circuit faults.

## **2. Introduction**

Denmark is a relatively small country, but includes two HVAC transmission systems which are asynchronous to one another and interconnected via the Great Belt HVDC link. The one HVAC system is Denmark West which is directly connected to North Germany, part of the meshed continental grid, and includes the peninsula of Jutland and the island of Funen. The other HVAC system is Denmark East which is directly connected to Sweden, part of the Nordic grid, and includes the main island of Zealand and the islands of Lolland, Falster and Moen. Besides the HVDC link to Denmark West and the HVAC connections to Sweden, Denmark East is also connected to Germany via the Kontek HVDC link.

The main consumption centre is about the capital Copenhagen on the main island of Zealand. The largest location of wind energy is south to Zealand, i.e. on the islands Lolland and Falster and in the two large OWPP at Rødsand. Figure 1 shows the present stage grid map of Denmark East with the 2018 envisaged HVAC connection of the Kriegers Flak 600MW OWPP. Table 1 presents the electrical energy outlook of Denmark East.

The operation conditions which are recognised as critical for keeping short-term (dynamic) voltage stability are present in combination of high wind power production, large power transport via the transmission system, lack of synchronous generators in operation and a short-circuit busbar fault in the main 400kV substations. Specifically, the short-term voltage stability is chal-

lenged due to a significant share of fixed-speed wind turbines with induction generators, which are found in many onshore sites and also in the large 165MW OWPP at Rødsand 1 [1]. Such wind turbines have been commissioned before introduction of modern Grid Codes [2], [3] and have no active voltage support during grid disturbances. In low-voltage operation and high wind speeds, the wind turbines get easily over-speeded, which makes the induction generators absorbing reactive power from the grid and pulling the system voltage further down [1].

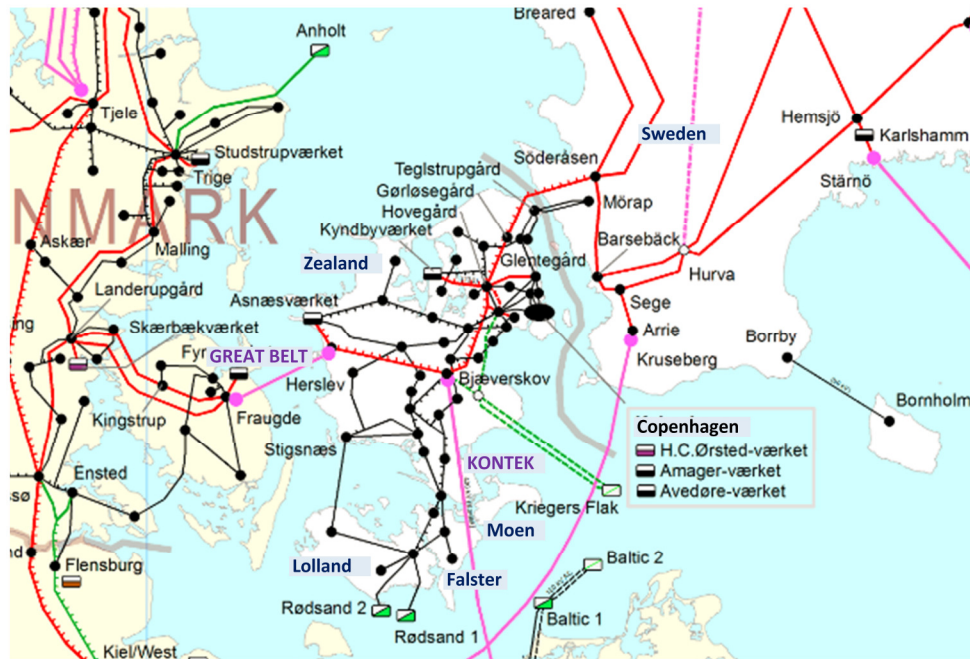

Figure 1: Denmark East and Kriegers Flak offshore wind power plant. Legend: — 400kV HVAC line, — 220kV HVAC line, — 150kV or 132kV HVAC line, — HVDC line.

Type	Nominal power capacity (MW)	Technology pr. nominal power capacity (MW)
Consumption excluding losses	2843	
Offshore wind without Kriegers Flak	372	Induction generation (Rødsand 1): 165 Converter-interfaced (Rødsand 2): 207
Offshore wind at Kriegers Flak	600	Converter-interfaced: 600
Onshore and near-coast wind	894	Induction generation: 356 Converter-interfaced: 538
Photovoltaics	255	Converter-interfaced without voltage support
Thermal power plants	1940	Largest unit: 450
Decentralised CHP units	315	Largest unit: 70
Kontek HVDC (import/export)	export / import 600/600	Line-Commutated Converter (LCC) HVDC
Great Belt HVDC (import/export)	export / import 600/600	Line-Commutated Converter (LCC) HVDC
Denmark East-Sweden (import/export)	export / import 1700/1300	400kV and 132kV HVAC

Table 1: Electrical energy outlook 2021 of Denmark East

Recognising the significance of dynamic voltage control in Denmark East and facing reduction of periods with centralised thermal power plants in operation, Energinet.dk has already established two synchronous condensers. The synchronous condensers are with the 270 MVA and 200 MVA capacities and connected to the 400kV system at the HVDC converter substations. In this approach, the synchronous condensers stabilize the transmission system voltage and also reduce risks of commutation failures of the LCC HVDC converters. Earlier, a Static Voltage

Compensation (SVC) unit has been established at the onshore 132kV substation of the Rodsand-1 OWPP in the island of Lolland, for improving voltage quality and stability [4].

### 3. Grid-connection outline

The Kriegers Flak OWPP will consist of two sections: the KFA section with a 200 MW nominal production capacity and the KFB section with a 400 MW nominal production capacity. Furthermore, the OWPP will have two connection points to the Danish transmission system: the Ishøj 400kV substation and the Bjæverskov 400kV substation. Figure 2 illustrates the grid-connection outline from the offshore KFA and KFB platforms to Denmark East. Further connection towards Germany via Kriegers Flak is not part of this paper.

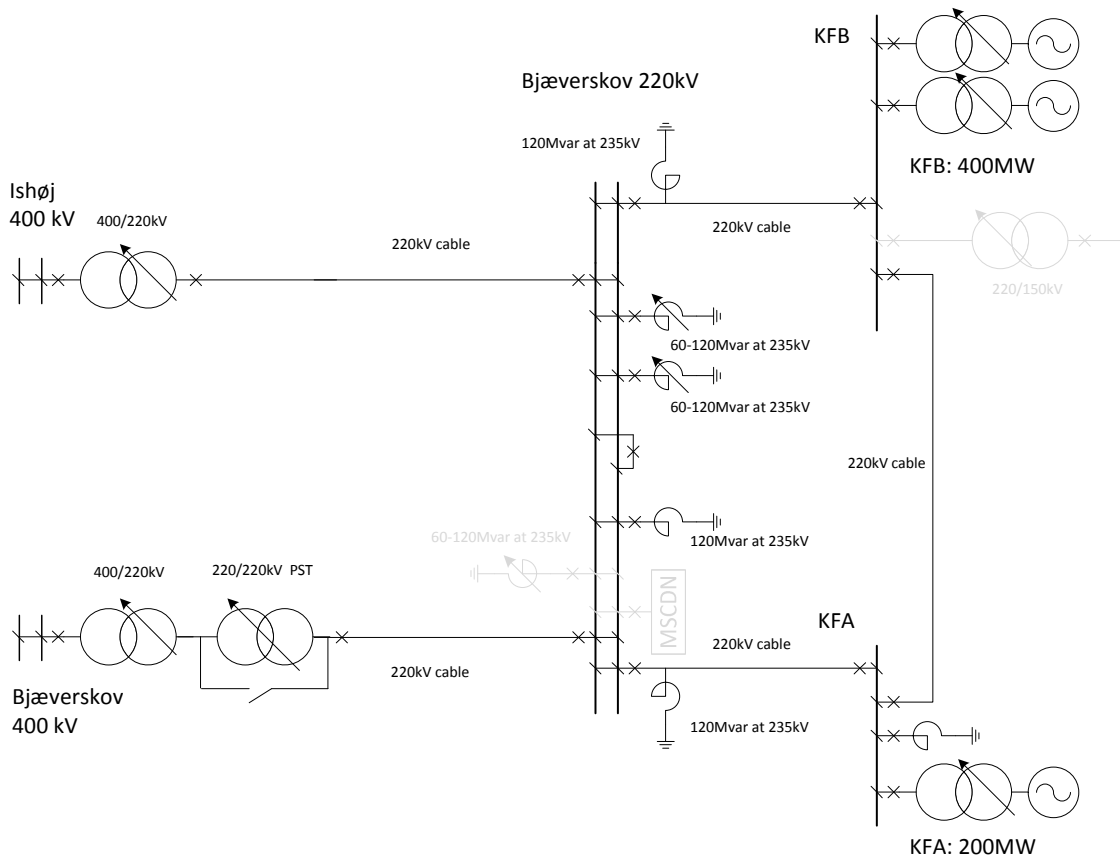

Figure 2: Kriegers Flak grid-connection outline to Denmark East.

The offshore platforms are connected to the Bjæverskov 220kV compensation substation via two approx. 80 km 220kV cables. Both cables are with submarine and land cable sections in series. The offshore platforms are connected via an 11 km 220kV submarine cable. From the compensation substation there is a 100 m short cable piece to the 220kV phase-shift transformer (PST) and to a 400/220kV transformer in Bjæverskov and there is an approx. 34 km 220kV cable to a 400/220kV transformer in Ishøj. In the compensation substation, there are both fixed and switchable reactors to compensate for reactive power generation of the 220kV cables.

Converter-interfaced wind turbines are an expected technology at Kriegers Flak. Such wind turbines will be with LVRT and reactive-current support of the voltage reestablishment during and after grid disturbances [3]. In normal grid operation, the wind turbines can be in one of the control regimes [3]: reactive-power control, power-factor control, or voltage control. From the

windfarm operator perspective, the reactive-power control regime within a limited range is preferred upon the voltage control regime due to better operation optimization, e.g. reducing power losses in the medium voltage (MV) collection network at limited reactive power exchange with the grid-connection 220kV system.

From the experience of Energinet.dk, which is gained from several OWPP in Denmark, the LVRT requirement and the reactive-current provision during low-voltage operation are not dispensable [4]. When the short-circuit fault is cleared and voltage in the transmission system re-establishes, the wind turbines are also able to re-establish the MV network voltage. Thus, the wind turbines remain grid-connected and quickly re-establish the active power delivery to the transmission system. In such a case, the active power balance remains with no need of immediate power reserves in the onshore transmission system. In normal operation, some reactive power delivery to the transmission system can be requested and expected upon agreement with the OWPP operator.

## 4. Approach

The study distinguishes between dynamic voltage stability of the Danish onshore transmission system itself and securing dynamic stability of the Kriegers Flak OWPP. The operation scenarios are set up for stressed operation conditions of the transmission system, which are large power transports superimposed by high wind power generation [1]. In such conditions, the fixed-speed wind turbines are imposed to instability in low-voltage operation [1]. No participation of centralised thermal power units has additionally stressed dynamic stability of the system, but such operation conditions are expected in the Danish transmission system in a near future.

The disturbances have been bus-bar short-circuit faults in the main 400kV substations. The fault duration is 100 ms. The bus-bar faults result in voltage dips and post-sequent tripping of affected transmission lines and transformers. Thus, the onshore transmission system shall recover back to normal operation in weaker conditions than before the faults.

Since the Kriegers Flak OWPP in normal operation conditions can be in different control regimes, the approach has been evaluation of the regimes on dynamic voltage stability of the OWPP itself following severe disturbances in the onshore transmission system.

### 4.1 Operation scenarios

The operation scenarios are prepared by superimposing the two consumption levels and the power transport directions, whereas the other operation conditions are kept unchanged. The two consumption levels are low (40%) and high (80%) of the maximum consumption. The two power transport directions are South → North, i.e. importing from Germany and fully exporting to Sweden, and North → South, i.e. fully importing from Sweden and exporting to Germany.

The other operation conditions are stressed, but not absolutely worst case. The power production in the offshore windfarms is 100%, whereas the power production in the onshore wind turbines is kept at a realistic level of 90% of the installed power capacity. The PV generation is 90%. The power delivery from the decentralised CHP units is 40%, which corresponds to that about 45% of the CHP units are at 90% of the nominal power generation and the remaining units are out-of-operation.

The active power exchange through the Great Belt HVDC link is used for balancing the East Danish system. Both synchronous condensers and the SVC unit are in operation. The operation scenarios are shortly illustrated in Figure 3.

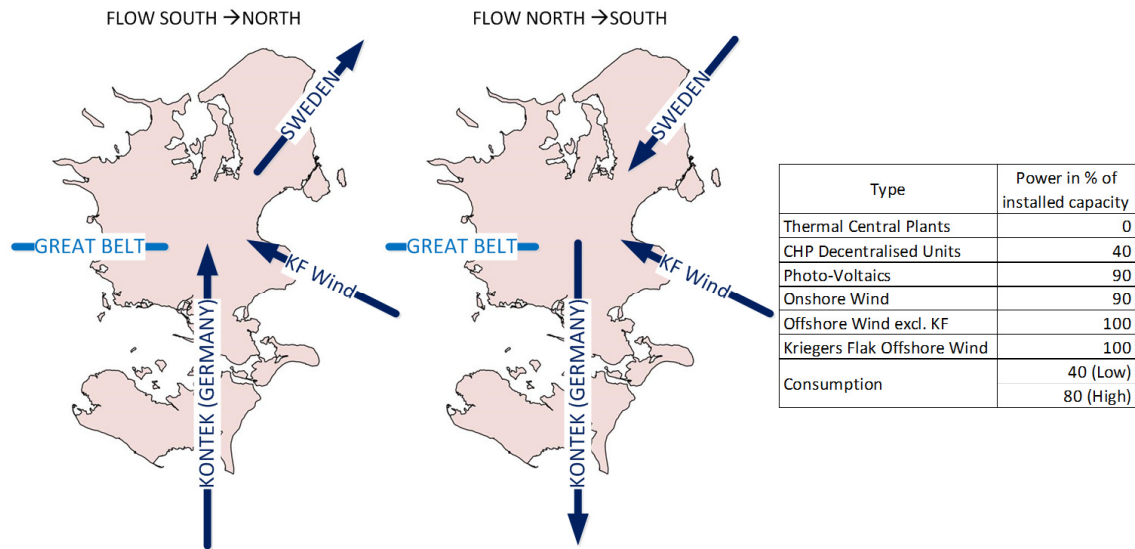

Figure 3: Illustration of operation scenarios

#### 4.2 System protection schemes

At present, Denmark East utilizes system protection schemes (SPS) for stabilizing voltage and frequency in severe disturbances in stressed pre-conditions. The SPS of the Great Belt HVDC link is included into this study, because the applied operation scenarios utilize combinations of export and import power flows through the HVDC link itself as well as between Denmark East and Sweden, which will arm and execute the SPS.

The SPS gets armed when the active power flows have exceeded given thresholds and the system conditions are either N or N-1, which is illustrated in Figure 4. When the SPS is armed and the system condition changes into either N-1 (from being N) or N-1-1 (from being N-1), the SPS gets executed. Transition from N (or from N-1) into N-1 (or to N-1-1) may relate to post-sequent tripping of transmission lines after bus-bar faults.

The SPS execution implies that the Great Belt HVDC link does run-back of the active power transport, which is fast suppressing of the active power transport through the link from the given level down to the lowest possible level without reversing the power direction. The SPS execution shall reduce the power exchange between Denmark-East and Sweden after outage of vital transmission lines, reduce the stressed conditions of the power transport through the Danish transmission system, and enforce voltage recovery in Denmark East.

Though the SPS have proven their positive impact on improving the short-term voltage stability in Denmark East, their utilization, adjustment and expansion to new system protection schemes shall be treated with care. New SPS shall be designed and coordinated with the already existing SPS within the same area in such a way that there is no unwished interaction between the SPS. Execution of the one SPS shall not cause any counteraction from the other SPS. Adjustment of existing and expansion to new system protection schemes are tasks for several relevant TSOs.

The HVAC grid-connection of the OWPP is an internal Danish case and does not involve foreign interests. Thus, no new SPS has been included into this voltage stability study.

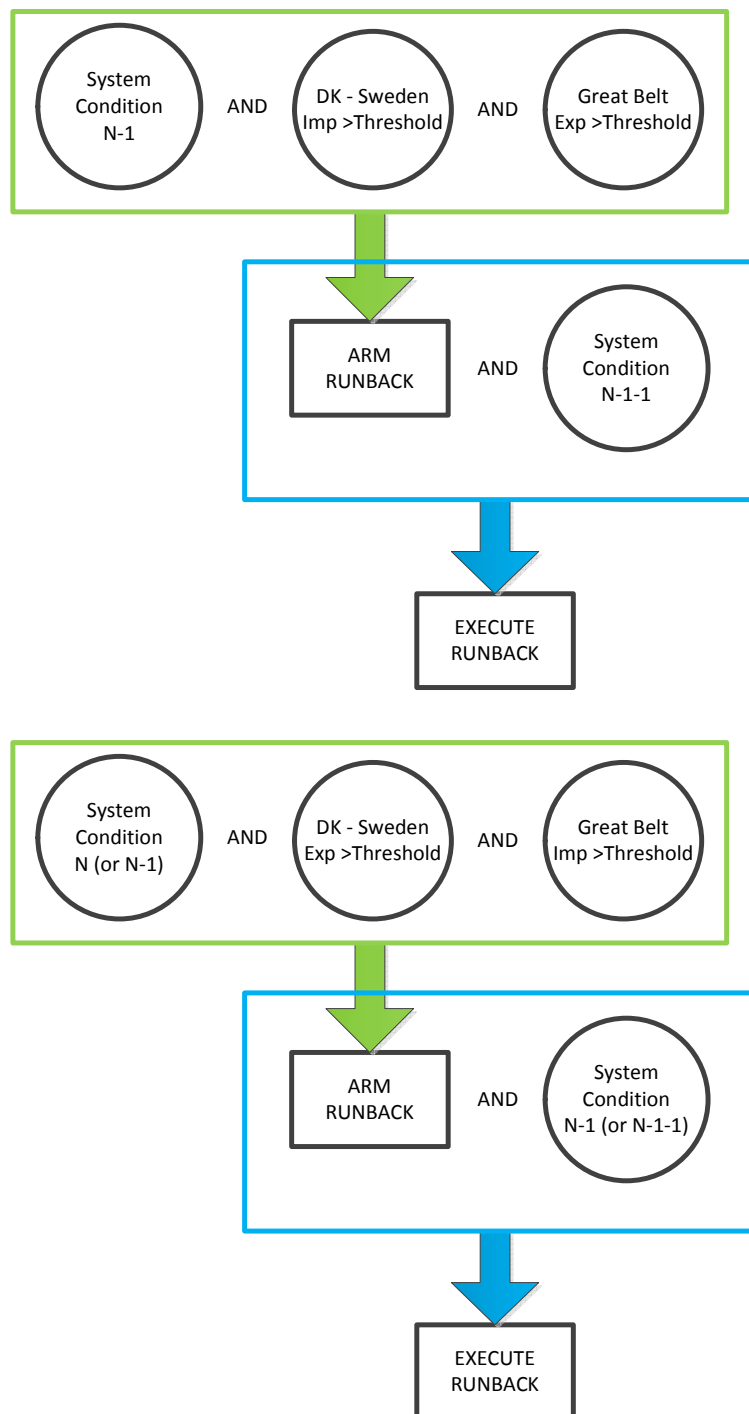

Figure 4: Illustration of the system protection schemes utilizing the Great Belt HVDC link

### 4.3 Voltage behaviour and stability

Figure 5 presents simulated voltage behaviour in the 400kV system of Denmark East following a bus-bar short-circuit fault. The study has confirmed the significance of the Great Belt HVDC SPS for keeping dynamic voltage stability in Denmark East at bus-bar short-circuit faults. The

SPS enables relaxation of the Danish transmission system after a voltage dip and post-sequent tripping of transmission lines, which contributes to re-establishment of the grid voltage.

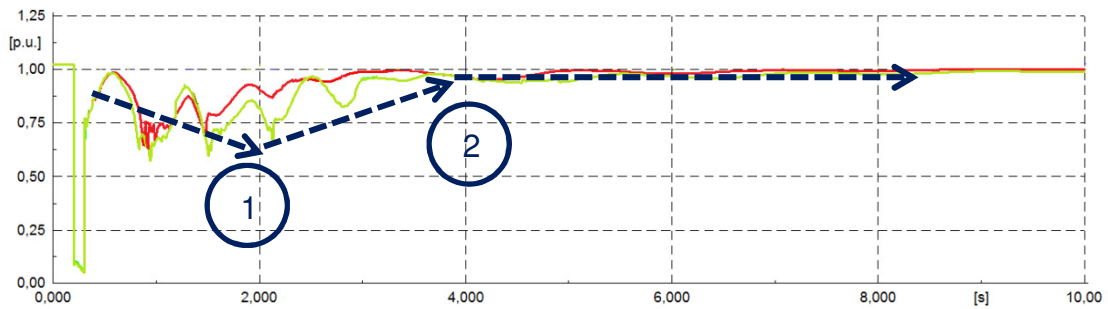

Figure 5: Simulated voltage behaviour in the 400kV system of Denmark East after a bus-bar fault. Influence of the LVRT procedure of the Rodsand-1 OWPP: mark 1 - voltage decays until the LVRT procedure gets started; mark 2 - voltage recovers where the LVRT procedure is completed. Influence of the SPS of the Great Belt HVDC link: ■ - SPS is not applied and voltage decays, ■ - SPS is applied and voltage recovers faster.

The study has also confirmed the significance of the LVRT procedure of the Rodsand-1 OWPP for the voltage recovery in Denmark East [1]. The LVRT procedure utilizes a fast reduction of the mechanical power and reduction of the active power infeed from the OWPP into the grid at low-voltage operation. The active power infeed is reduced down to 20% of the nominal power capacity by less than 2 sec. The LVRT procedure prevents over-speeding and reduces reactive power absorption by the induction generators of Rodsand-1, and enforces the grid voltage re-establishment [1]. The OWPP goes into normal operation, i.e. the pre-fault active power infeed, when the grid voltage recovers back to normal.

The above-presented measures of dynamic voltage re-establishment are important and significant, but already tried-and-proven methods for Denmark East. From this perspective, the study has neither exposed worsening nor found improvement of dynamic voltage stability in Denmark East, which should relate to the HVAC grid-connection of the Kriegers Flak 600MW OWPP. The voltage reestablishment process may take several seconds and followed by oscillations, i.e. the dynamic voltage recovery is slow. Slow voltage recovery in the onshore transmission system may later impose additional recommendations for the control regime of the OWPP.

Figure 6 compares simulated behaviours of the Kriegers Flak wind turbines after a bus-bar short-circuit in Denmark East for the two (normal) operation regimes: (i) voltage control and (ii) reactive-power control. As seen, the voltage and active power show faster and securer reestablishment when the wind turbines are in the voltage control regime (normal grid operation). Being in the reactive-power control regime, the voltage still recovers, but the wind turbines may tend more re-entering, i.e. leaving and then going into, the LVRT regime, which may cause disconnection.

Though the voltage control regime in normal grid operation has not been requested, but still the regime is recommended for the Kriegers Flak wind turbines.

This study has not concluded cases which would result in not-recovered voltages in Denmark East or at Kriegers Flak, at the applied operation conditions.

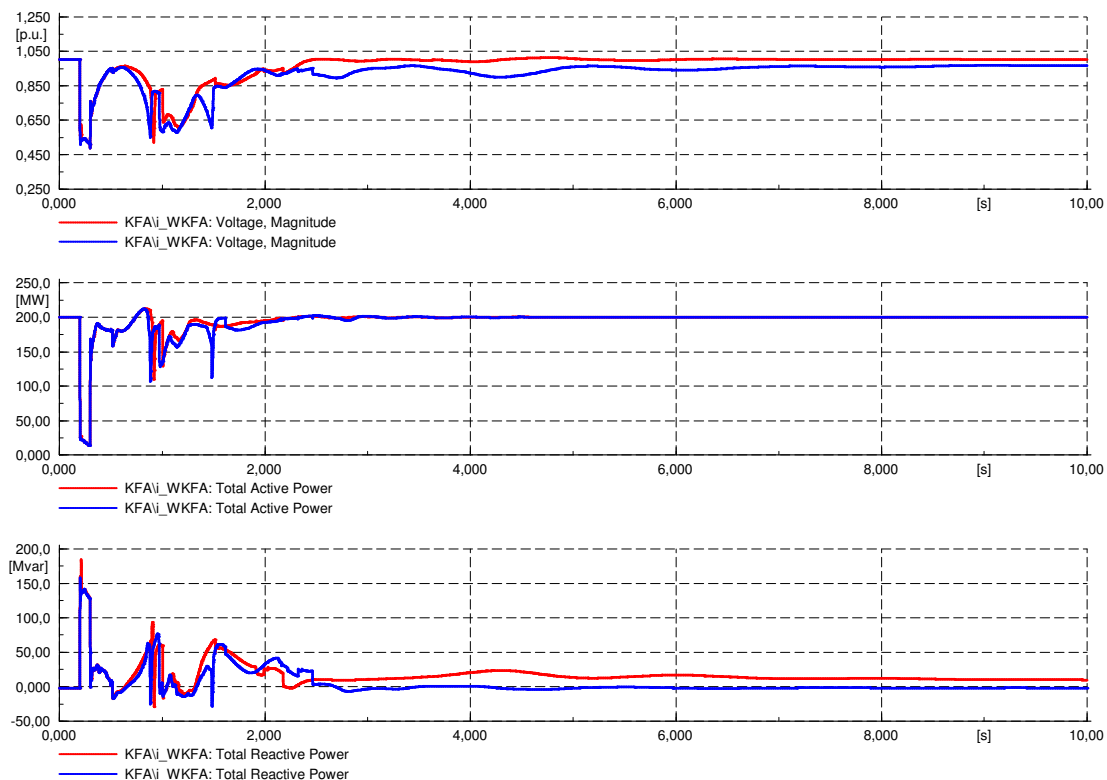

Figure 6: Comparison two different control regimes in normal operation of the Kriegers Flak wind turbines: ■ – voltage control, ■ – reactive-power control.

## 5. Conclusion

The dynamic stability study for the HVAC grid-connection of the Kriegers Flak 600MW offshore wind power plant (OWPP) to the East Danish transmission system has been conducted. When completed by 2018, the Kriegers Flak OWPP will be the largest power production unit in Denmark East. The study is based upon operation scenarios without participation of centralised thermal power plants, so that the consumption is covered by wind power, decentralised CHP and photovoltaics and balanced by the connectors to foreign transmission systems.

The study has shown that dynamic voltage stability of the transmission system is maintained by the tried-and-proven methods such as advanced utilization of system protection schemes, the LVRT procedures of the wind turbines. Furthermore, the dynamic voltage stability relies on contributions from the already established synchronous condensers. The study does not expose needs of additional synchronous condensers right away. The study recommends that the Kriegers Flak OWPP should be in the voltage control regime in normal grid operation for securing fast and secure voltage reestablishment within the Kriegers Flak OWPP network after severe disturbances in the Danish onshore transmission system.



## 6. References

- [1]. Akhmatov V. "System stability of large wind power networks: A Danish study case". *International Journal of Electrical Power and Energy Systems* 2006; 1:48-57.
- [2]. "Commission Regulation (EU) 2016/631 of 14 April 2016 establishing a network code on requirements for grid connection of generators". *Official Journal of the European Union* 27.4.2016; L112:1-68.
- [3]. "Technical regulation 3.2.5 for wind power plants with a power output above 11 kW". Energinet.dk Transmission System Operator of Denmark. Published UK edition. 30.03.2015. Doc. No. 13/96336-43:1-98.
- [4]. Akhmatov V. "Experience with voltage control from large offshore windfarms: The Danish case". *Journal of Wind Energy* 2009; 12:692-711.

## Appendix A – Transmission system model validation

The results of dynamic stability studies are fully reliable on quality of the dynamic simulation models. Therefore, this paper is extended with a short overview of a validation case of the Danish transmission system model. The validation case represents a 3-phase short-circuit fault in a 132kV substation in the main island of Zealand (the 132kV substation Gørløse north to Copenhagen), i.e. in the transmission system of Denmark East. The short-circuit fault occurred on August 19<sup>th</sup> 2015 at 12:33 PM.

The transmission system model with representations of the substations, lines and cables, transformers, generation units and consumption was acquired from the model database of Energinet.dk. The operation scenario of the Danish system just before the fault occurrence was set up with the usage of the SCADA measurements and the transient fault recorders (TFR) under the main substations. The SCADA measurements were also applied for distinguishing which grid components were in-service, respectively, out-of-service, and for enabling a correct load-flow solution as a starting point of the event. The TFR data were used for definition of the fault duration and protection in the given 132kV substation.

Figure 7 shows the measured and simulated voltage magnitudes in the main 400kV substations of Denmark East. The measured instant voltages and simulated RMS voltages were found in good agreement.

The presented validation case is among many other model validations performed by Energinet.dk and demonstrates that the simulation model of Denmark East is of a good quality, reproduces a correct level of the short-circuit capacity (matching a correct voltage dip magnitude under the fault), and reproduces a correct post-fault voltage behaviour (matching the voltage control systems in the transmission system).

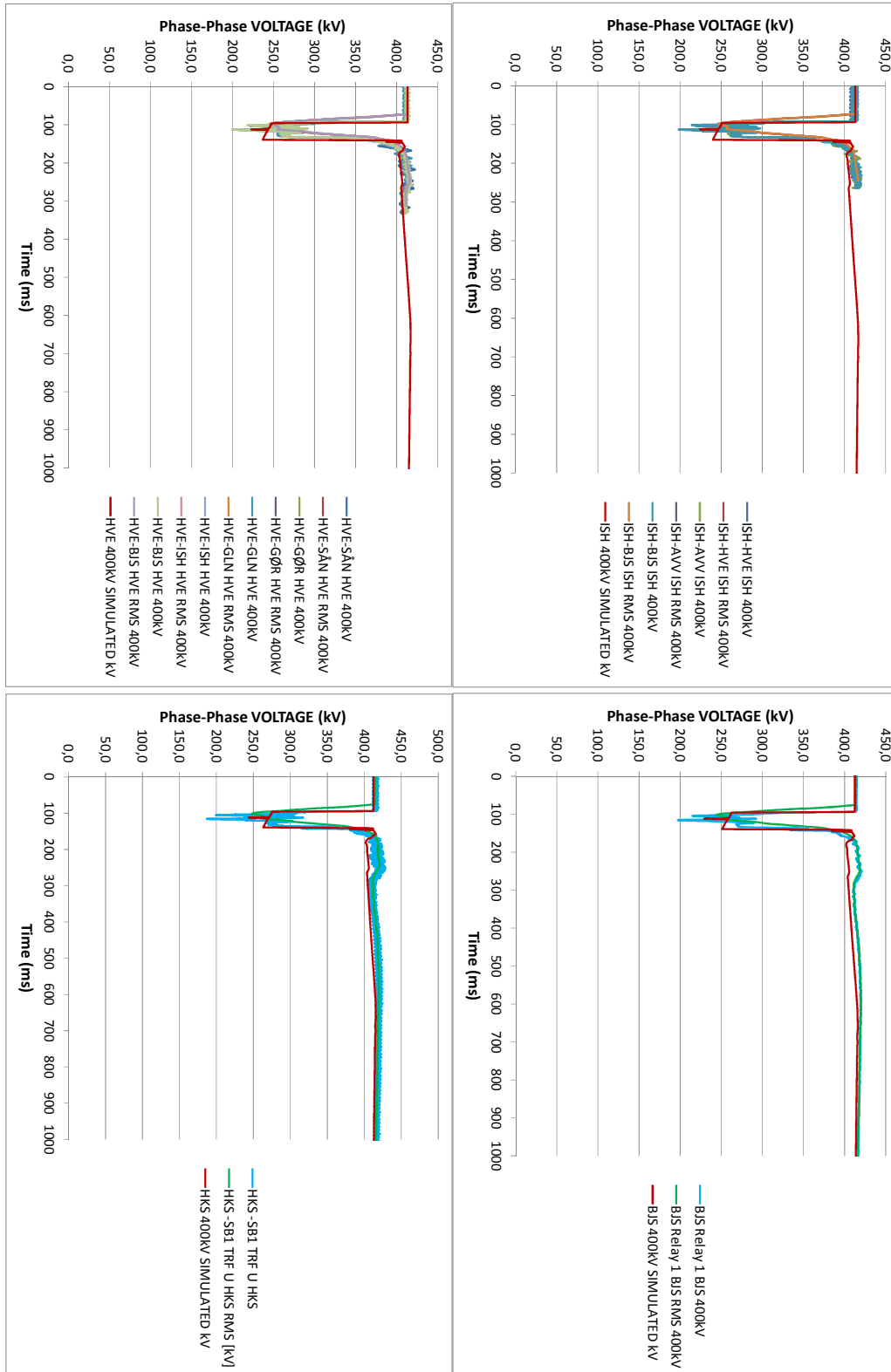

Figure 7: Comparison of measured instant voltages and simulated RMS voltages in the main 400kV substations in the East Danish transmission system. NB: substations BJS400 and ISH400 denote the grid-connection points of the Kriegers Flak OWPP.